

FAIRBANKS®

FB 2200 SERIES DIGITAL INSTRUMENT

FB 2200

DIGITAL INSTRUMENT



Fairbanks quality engineering and weighing precision at an extremely competitive price.



Visit our world...fairbanks.com



FAIRBANKS®

FB 2200 SERIES DIGITAL INSTRUMENT

EXCEPTIONAL FEATURES, LOW COST

Fairbanks exceeds industry's need for a basic commercial and non-commercial weight instrument with the new FB 2200.

While competitively priced, the FB 2200 has features typically offered only in higher priced digital instruments, such as: Time and Date, a Six-button Front Panel Display, and a large 1" LCD Display that promotes ease of visibility.

INDUSTRIAL APPLICATIONS

The FB 2200 is designed and engineered with a variety of industries in mind, such as:

- Agriculture
- Chemical
- Warehousing
- Pharmaceutical
- Shipping & Receiving

The FB 2200 is ideal for dozens of basic applications, including:

- Digital Beam Scale Conversions
- Manual Batching
- Strength Testing
- Vessels
- Material Handling
- Industrial Hoppers



NTEP approval for any application makes the FB 2200 the cost-efficient solution for commercial weighing needs.



ABS ENCLOSURE

The ABS model comes standard with a desk mount. An optional wall mount bracket is available.

FB 2200

INSTRUMENT FEATURES:

NEMA 4X
Stainless Steel
enclosure for
washdown and
other hostile
environments.

Knurled knob
for easy tilt
adjustment.

Spacer
provides
easy
cleaning
between
instrument
and
mounting
bracket.

Versatile wall
or desk mount
bracket.

Rubberized foot
for desk mounting.

The Stainless Steel model's Tilt Mount bracket offers a variety of wall or desk mounting options.

The FB 2200 performs exceptionally in basic bench and floor scale applications.

REDUCED INSTALLATION TIME

The FB 2200 features a cage clamp connector for fast, easy base-instrument connection. No need to solder wires into tiny connectors as required with similar, competitive products.

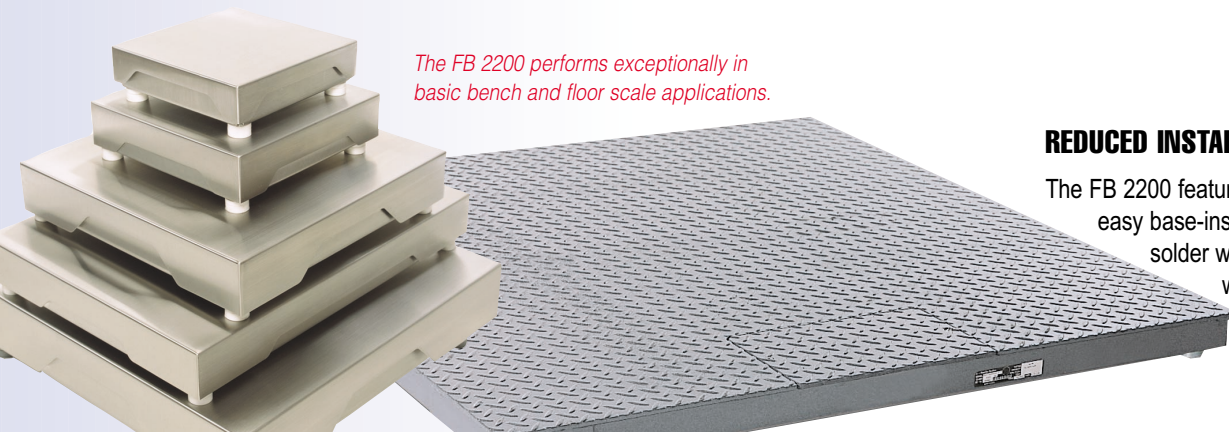

FB2200

Simply the Best!

INSTRUMENT FEATURES:

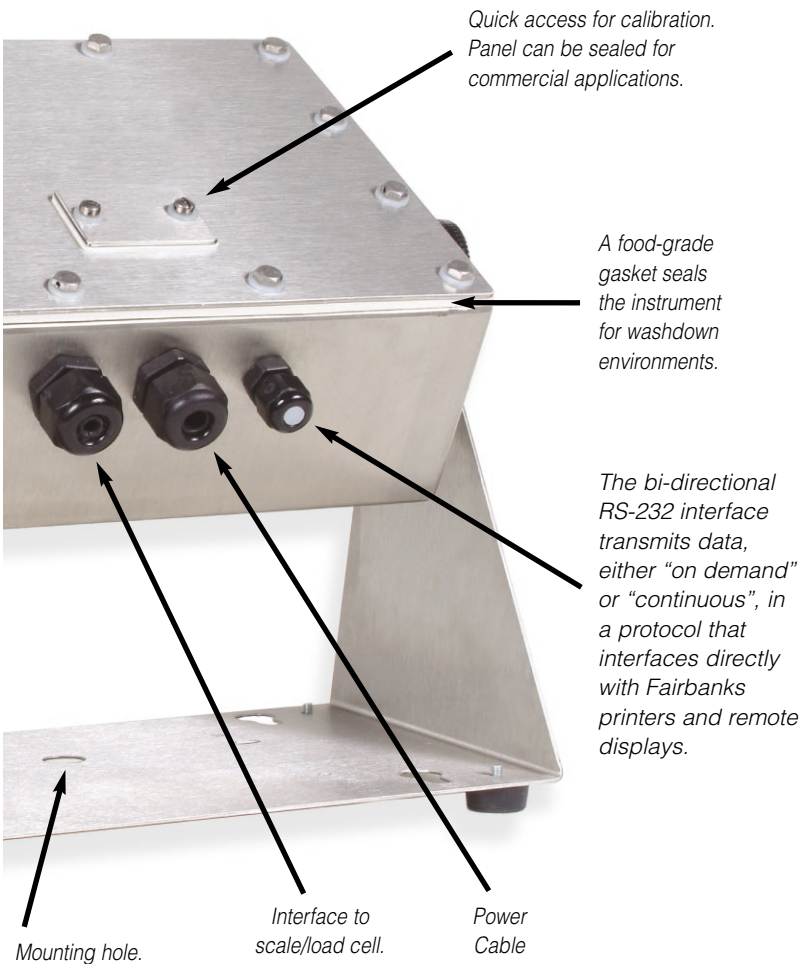

STAINLESS STEEL ENCLOSURE

The Stainless Steel FB 2200 has a NEMA 4X rating. Its stainless steel enclosure protects the instrument when used in washdown and caustic environments. A tilt bracket, that offers both desk and wall mount, comes standard.

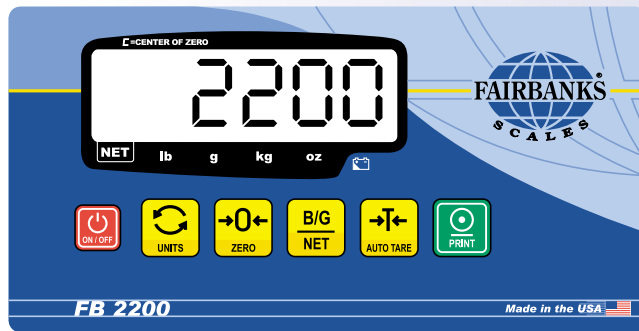

FUNCTION KEYS

Six function keys provide quick access to commonly used features and reduce the time it takes to get a scale "up and running."



On/Off key.



Units key allows operator to quickly choose between lbs, oz, kg, g and lbs/oz.



To establish "0" reading prior to a new weightment.



Used to toggle between Gross and Net weights.



Allows operator to weigh a material without weighing the material's container.



Bi-directional RS232 output to a printer, PC or Remote Display. Output format compatible with UPS and other shipping software.



FAIRBANKS®

FB 2200 SERIES DIGITAL INSTRUMENT

ABS MODEL DIMENSIONS

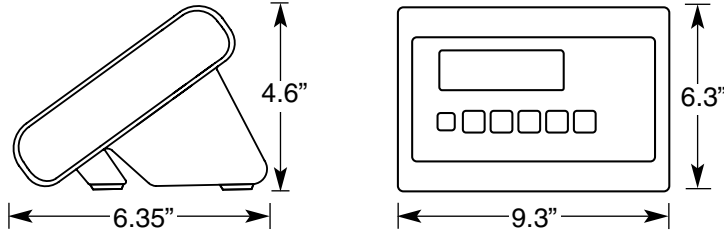

SPECIFICATIONS

Enclosure	ABS, Black NEMA 12; SS NEMA 4X
Display	1" LCD, 6-digit
Pushbutton Keys	On/Off, Units, Zero, B/G Net, Auto Tare and Print
Units	lbs, oz, kg, g and lbs/oz
Graduation Size	0.001 lb to 50 lbs.
A/D conversion	66 per second
Internal Resolution	1,000,000
Displayed Divisions	100,000d (non-commercial) 10,000d (commercial)
Excitation	5 VDC to scale
Load Cells	Eight (8) 350Ω load cells; or Sixteen (16) 700Ω load cells
Power Requirements	9 VDC @ 500mA (AC Adapter supplied)
Mounting	ABS (Desk mount standard, wall mount optional) Stainless Steel (Tilt bracket for desk/wall standard)
Communications	One RS-232 bi-directional
Approvals	NTEP; Canadian Weights and Measures

STAINLESS STEEL MODEL DIMENSIONS

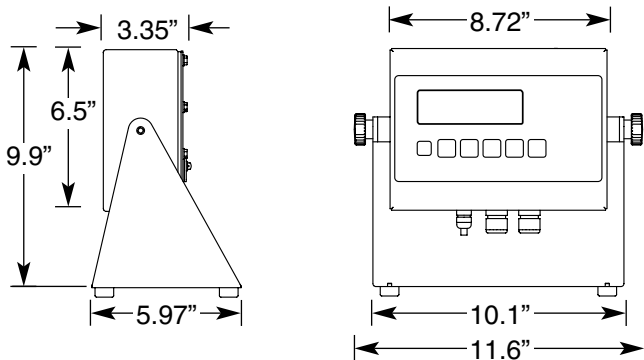

FAIRBANKS REACHES 175 YEAR MILESTONE

In 1830, Thaddeus Fairbanks revolutionized commerce and changed the world by inventing the Platform scale and founding the company that still bears his name. The Platform scale allowed for the rapid and accurate weighing of commodities by the

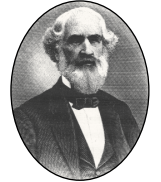

wagonload, creating equity in commercial transactions.



Throughout the 1800s, Fairbanks continued to supply

the world with weighing solutions across a broad range of industries and was established as the leading manufacturer of scales.

Fairbanks again led the way during the 20th Century with innovations that pushed the modern envelope — merging electronic, digital and computer technology with mechanical weighing equipment.

Today, Fairbanks Scales stands at the forefront of the weighing industry and is recognized as the oldest, continuously operating, industrial manufacturing company in the United States.

We, at Fairbanks, are proud of our legacy and the continual innovation that has made our company a leader in industrial weighing for 175 years.

Leasing

The FB 2200 and all other Fairbanks Scales products can be leased through Fairlease, Fairbanks' easy-to-use equipment leasing program. Consult your Fairbanks representative for details.

Your Fairbanks Scales Authorized Representative is:

Call toll-free for the representative nearest you:

(800) 451-4107

Call between 8:00 a.m. – 5:00 p.m. CST

Corporate Offices: 821 Locust • Kansas City, MO 64106 • (816) 471-0231

www.Fairbanks.com

